

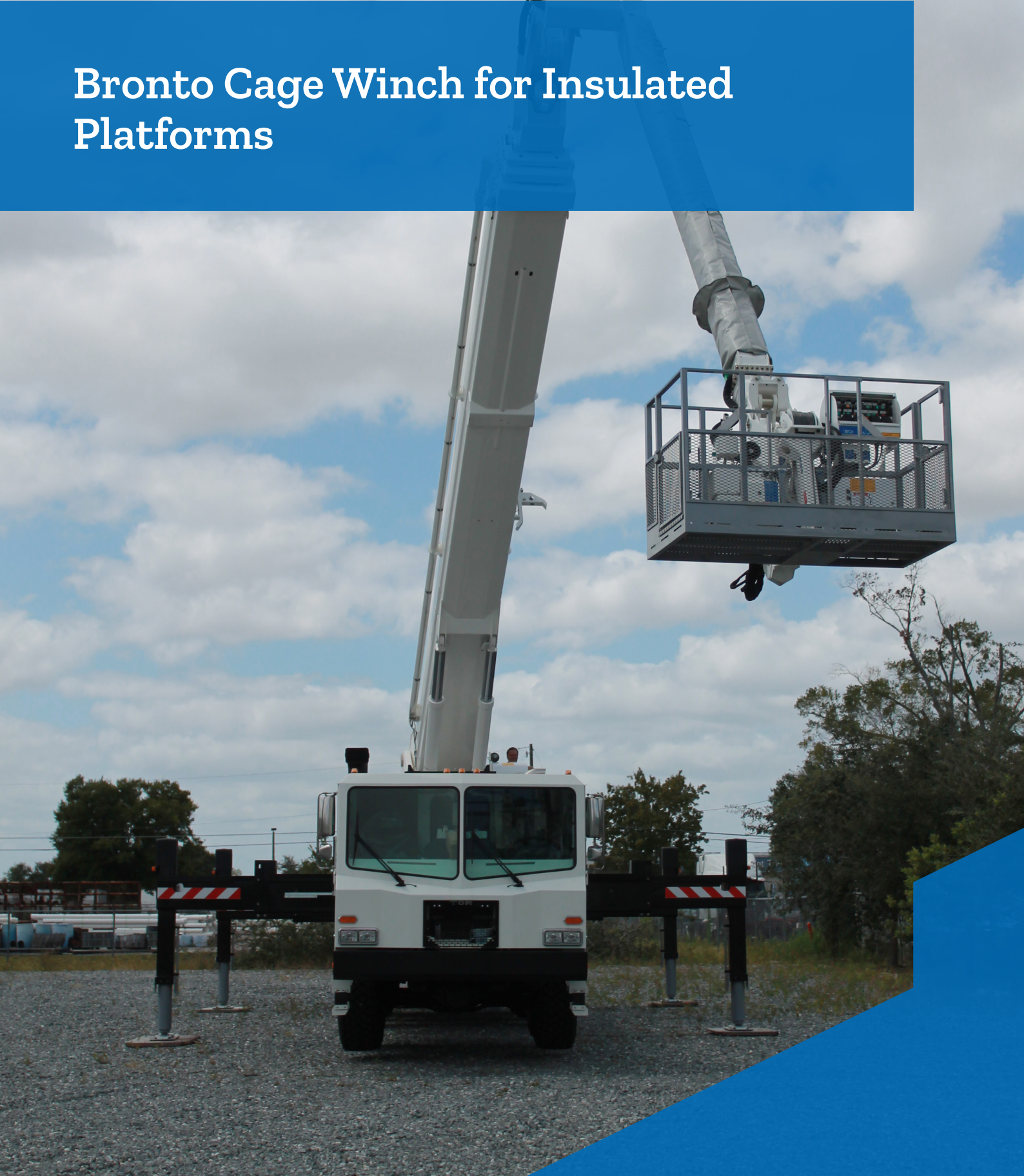

Bronto Cage Winch for Insulated Platforms



Bronto Insulated Cage Winch

High cage capacity does not enhance the usability of a machine without adequate tools for handling those loads. Therefore, Bronto has strived to develop a whole range of add-ons that take full advantage of the high work load of the platforms. The 680kg cage winch for insulated aerial platforms is easy to operate and an essential tool for carrying heavy loads.

Features

- Material handling capacity of up to a 680 kg* (SI219HDT-C 400 kg)
- Hydraulic operation, independent from external power sources
- Manually extendable lifting jib
- Fixed mounting to the cage. Slewing possible with cage slewing
- Dyneema rope 60 metres
- Adjustable lifting jib
- The cage winch stores with the jib folded down by the railing to save space.
- Not insulated
- Suitable for insulated Bronto aerial platforms

*Actual capacity depends on cage load

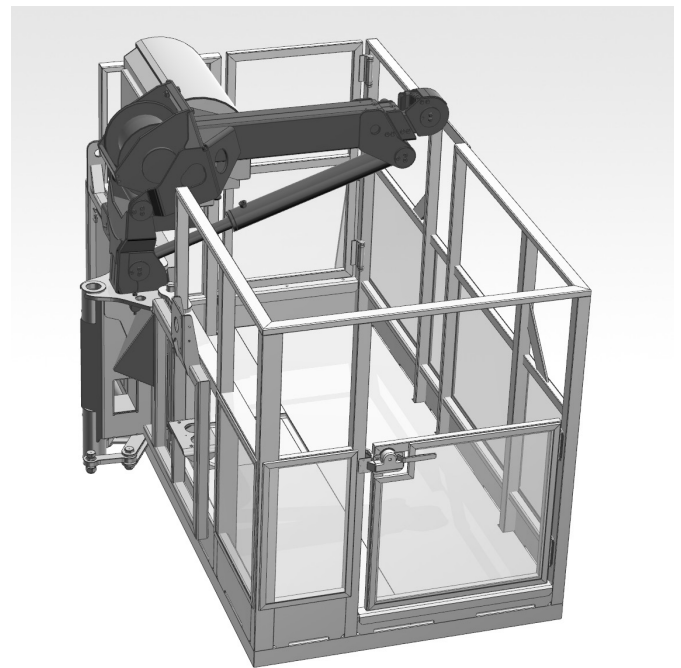
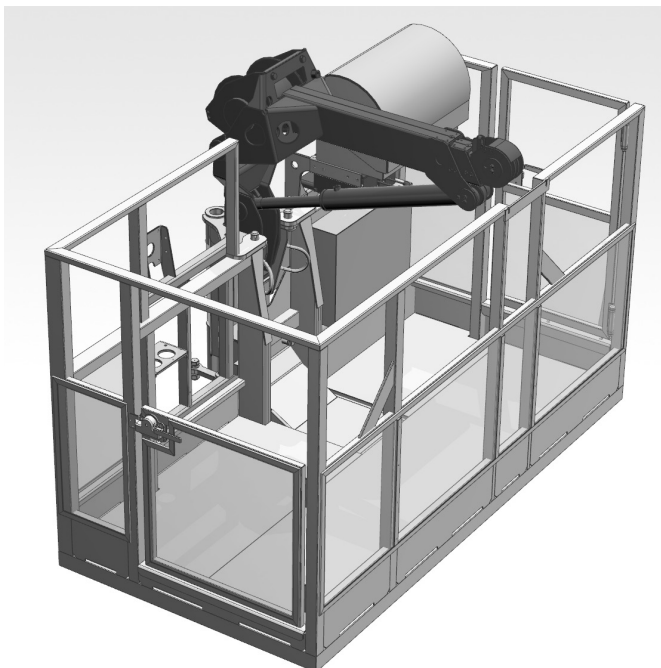

sales@brontoskylift.com

Technical data and illustrations subject to change without notice.

www.brontoskylift.com